

**\*\*\* IMPORTANT INFORMATION \*\*\***

**BEFORE YOU START**

Installation should be performed by a competent person only. This product could be dangerous if incorrectly installed.

Check the pack to ensure all of the components are included.

When you are ready to start, make sure that you have all of the correct tools to hand, have plenty of space, and that the area for building is clean and dry.







Do not rush! Read these instructions first and run through the sequence before you begin. Assembly should be carried out in the steps shown in the following diagrams, constructing one unit at a time and keeping fittings together to avoid loss. Lay large panels on the floor using the packaging for protection. Do not overtighten screws, as this may damage the cabinet.

If any items are missing, or problems arise with fitting, please call the **Manufacturers' Helpline on 01769 575500**.

To clean - use mild soap and water only.

Do not use abrasive cleaners.





**HARDWARE:**

- 24 x **A**  15mm
- 24 x **B** 
- 12 x **C** 
- 18 x **D**  15mm
- 8 x **F**  30mm
- 2 x **H** 
- 8 x **J** 





Please use scissors to open the bag of fittings and then empty the contents into a bowl, so that they do not get lost!

**LEGS:**

- 4 x **W** 
  - 4 x **X** 
  - 2 x **Y**\* 
  - 2 x **Z**\* 
- \*Joined together in the pack

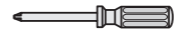
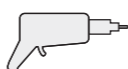
**MINIMUM TOOLS REQUIRED:**

-  CROSS HEAD SCREWDRIVER
-  DRILL & DRILL BITS (3mm & 5mm)
-  HAMMER
-  SPIRIT LEVEL

**PANELS:**

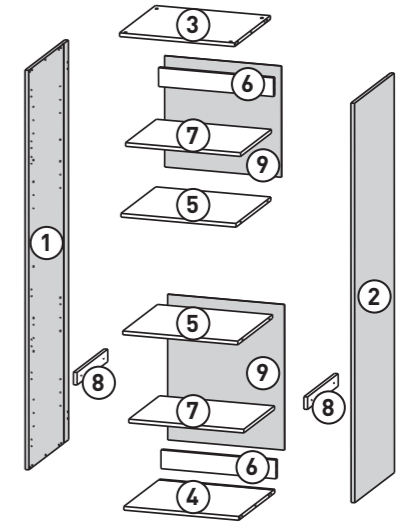

- 1 x **1** LH End Panel
- 1 x **2** RH End Panel
- 1 x **3** Top Panel
- 1 x **4** Base Panel
- 2 x **5** Fixed Shelf
- 2 x **6** Back Rail
- 2 x **7** Shelf
- 2 x **8** Support Rail
- 2 x **9** Back Panel

 Panels are supplied in a separate End panel pack

**IMPORTANT: CAM FITTING AND LOCKING:**

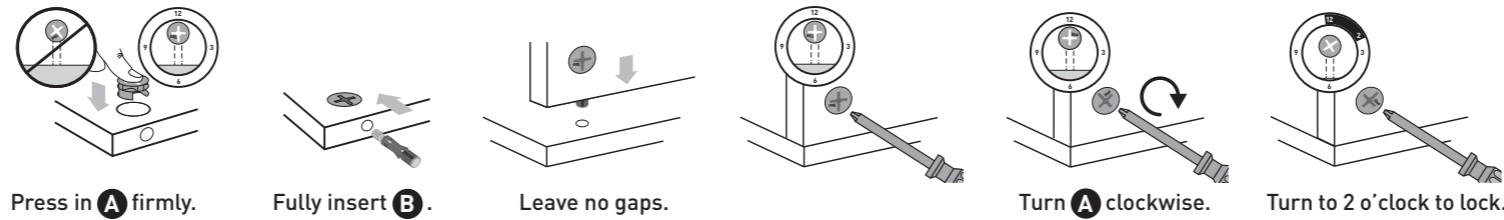

**STEP 1:**



Inset **A** into panels **3**, **4**, **5** and **6** as shown.

Then insert **B** and **C** into panels **3** and **4**, and **B** only into panels **5** and **6**, as shown.

**IMPORTANT:**

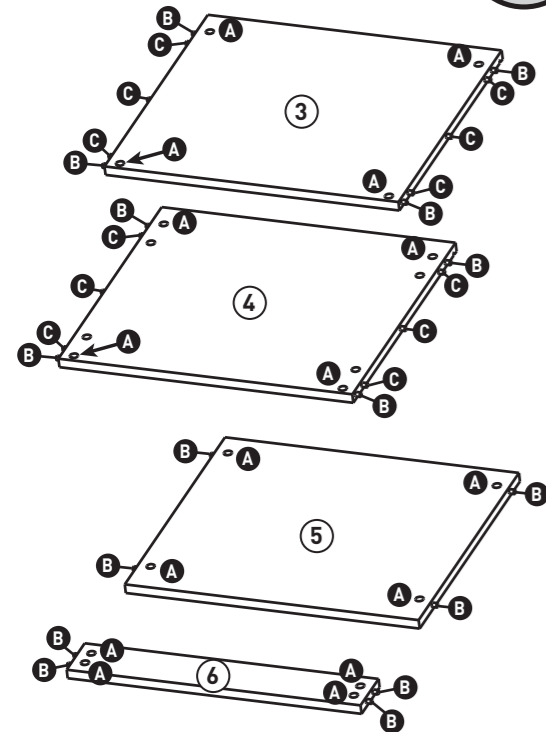
When fitting **A** Arrow points to outside edge.



-  600mm nominal opening
-  900mm nominal opening

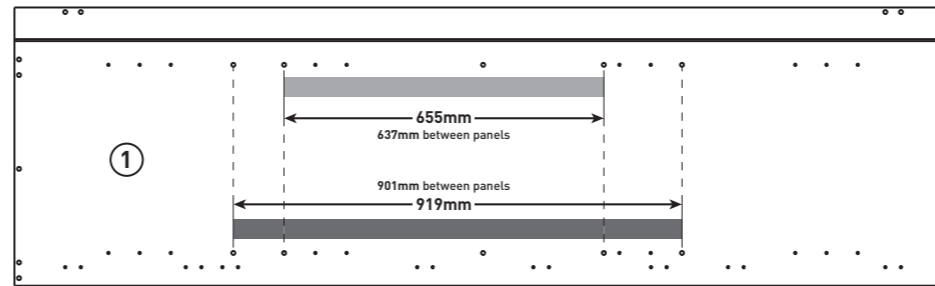

**STEP 2:**

Fit panels **3** and **4** to panel **1**, as shown.

Tighten the cams as you go (refer to cam fitting and locking section above).

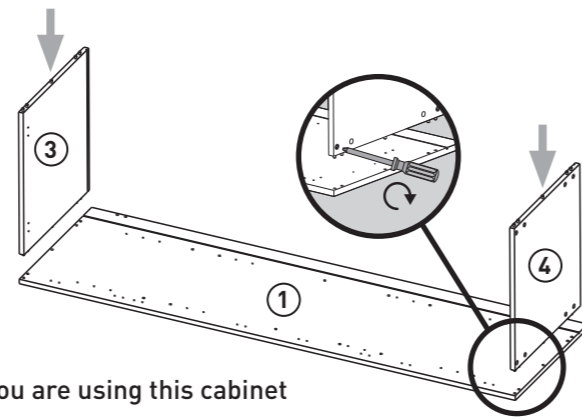

If you are using this cabinet for an integrated fridge / freezer, you should leave out panels **5** and **9**, during the construction process.

**STEP 3:**

Fit both panels **5**, to panel **1**, in the correct positions as shown in above. Tighten cams.

The back panels **9** will need to be cut to size, to suit your opening size. Carefully slide both of these panels into the grooves, and fix into place.

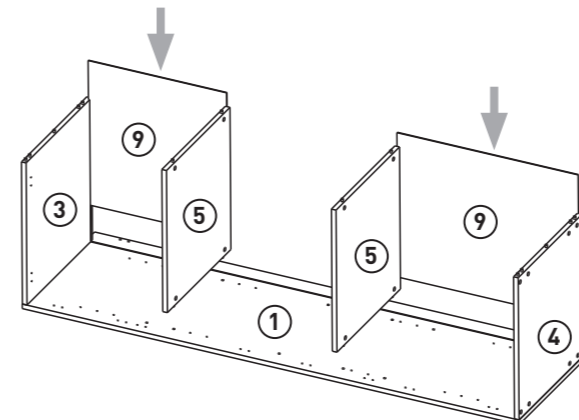

**STEP 4:**

At the back of the cabinet, fit panels **6** to panel **1**, as shown, and tighten cams.

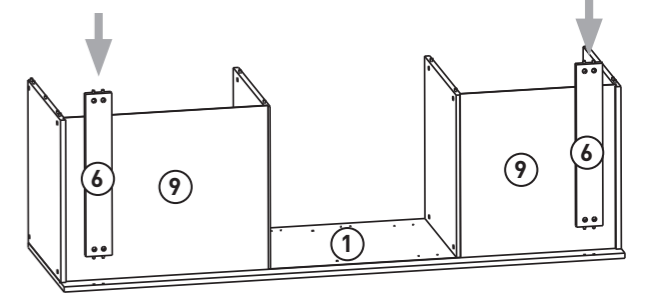

**STEP 5:**

Fit panel **2** to panels **3**, **4**, **5** and **6**, and tighten cams.

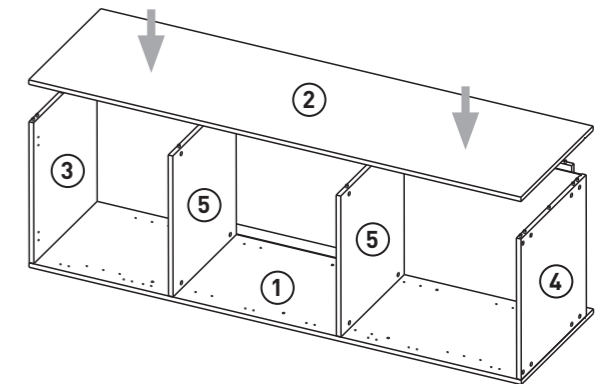

**STEP 6:**

Finally, fit panels ⑧ to panels ① and ②, using screws ⑤, underneath the lowest panel ⑤, as additional support for the oven.

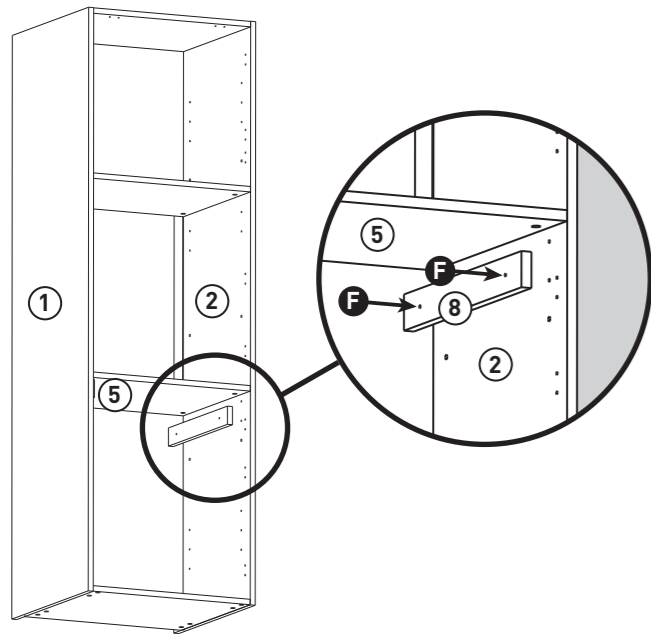

**FITTING OF LEGS**

Position ① as shown, lip on underside of end panels ① and ②.

Ensure screwhole is not over panel join.

Tap in the central plastic lug.

Drill pilot holes 3mm x 3 positions.

Secure with ① screw x 3 positions.

Then push leg ② into leg boss ③.

Rotate to adjust height.

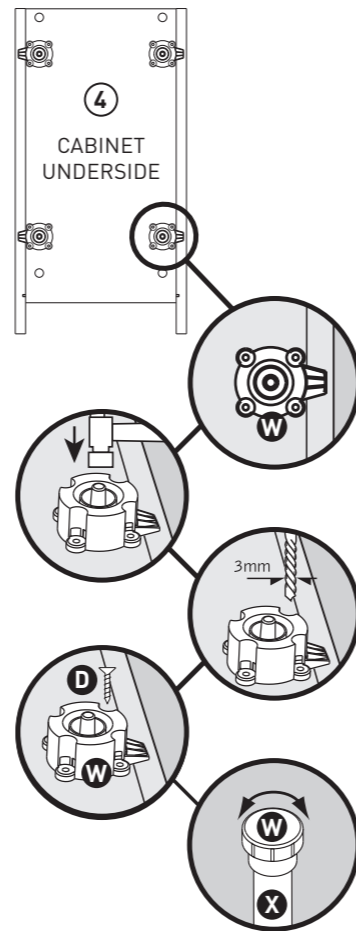

 Care should be taken when fitting legs and fitting to wall, as unit may be heavy.

**JOINING & LEVELLING**

**LEVELLING:** All legs are pre-set at 150mm. Using a spirit level, rotate the bottom of the legs to adjust up and down, to level the unit.

**JOINING:** Mark 15mm on a 3mm dia. Drill bit with masking tape. Drill between the 2 holes drilled for the hinges, through one cabinet side. Using clamps if necessary, join the cabinets together with 2 x screws ④.

**FITTING TO WALL:** Position the brackets ⑤ at the back edge of the cabinet, and mark. Now drill a 3mm pilot hole, and fit the brackets ⑤ using screws ⑥. Use appropriate fixings (not supplied), to secure the cabinet to the wall (depending on wall type).

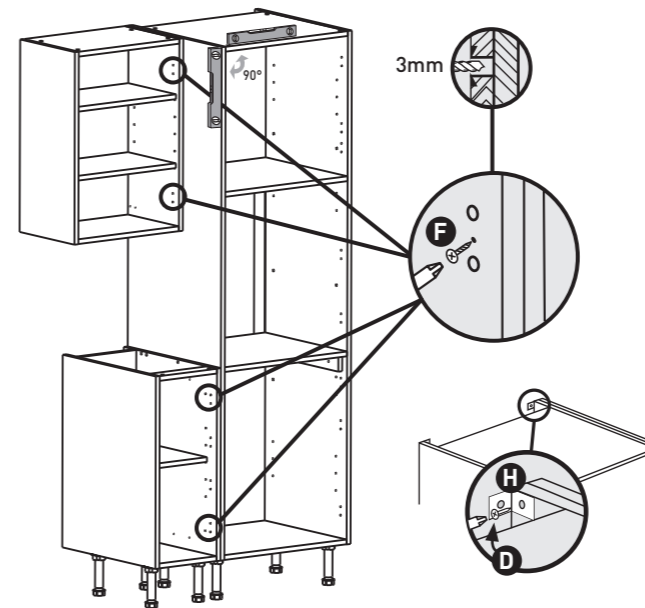

**SHELF FITTING**

Push shelf support ⑦ into chosen shelf position holes, 4 per shelf.

Tilt and slide in shelf.

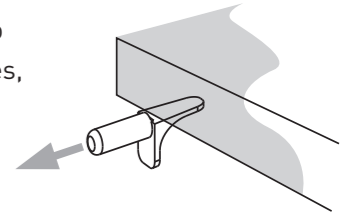

**PLINTH FITTING**

Lay plinth panel in front of cabinet.

Position plinth clip plate ⑧ opposite front cabinet legs.

Secure with 2 x screws ⑨.

Slide ⑩ into ⑧.

Stand plinth up.

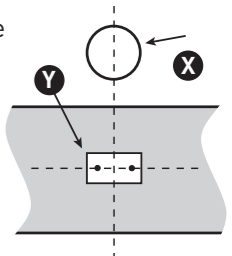

**INTEGRATED FRIDGE / FREEZER FITTING**

When fitting an integrated fridge / freezer to this cabinet, it may be necessary to raise your appliance within the cabinet, to achieve correct operation of the doors.

The unused panels can be utilised, to achieve this.

**NOTES:**